

BLADE REPAIR INSTRUCTION BOOKLET

Contents

Section I: Removing a Blade

Refer to this section if you need to remove the blade from an oar shaft.

Section II: Bonding a Blade

Refer to this section if you need to bond a new blade onto an oar shaft.

Section III: Repairing a Dent in Edge of Blade

Refer to this section if your blade is dented along the blade edge.

Section IV: Repairing a Delaminated Blade

Refer to this section if a portion of the skin of the blade is peeling off the blade.

Section V: Replacing an Old-Style Vortex Edge with an Old-Style Vortex Edge

Refer to this section if you need to replace or glue an old-style Vortex Edge.

Section VI: Replacing an Old-Style Vortex Edge with a Cap-Style Vortex Edge

Refer to this section if you are replacing an old-style Vortex edge with a cap-style Vortex edge.

Section VII: Replacing a Cap-Style Vortex Edge

Refer to this section if you are replacing a cap-style Vortex edge with a cap-style Vortex edge.

Section VIII: Painting Blades

Refer to this section if you would like to paint your blades.

Note: The most accurate way to check the pitch of your oars is with the Pitch Check available from Concept2. If you do not have the Pitch Check, the following instructions will enable you to check the pitch of your oars.

Section IX: Pitching Original Smoothie1 and Fat Blades

Refer to this section if you need to check the pitch of your original Smoothie1 or Fat blades.

Section X: Pitching Macon, Big Blade, Smoothie2 and Fat2 Blades

Refer to this section if you need to check the pitch of your Macon, Big Blade, Smoothie2 and Fat2 Blades.

Materials Needed	Procedure Overview
<ul style="list-style-type: none">• Propane torch• Draw knife or other strong knife	<ul style="list-style-type: none">• Heat blade to soften blade and glue• Use knife to cut away part of softened blade• Pull blade off• Clean up glue on shaft

Procedure

1. Heat the blade as follows:

- Apply heat to the blade where the shaft comes into the blade for approximately three minutes. Keep the flame moving evenly. See photo A.
- If blade starts to blister or burn, move the flame to another spot.

photo A

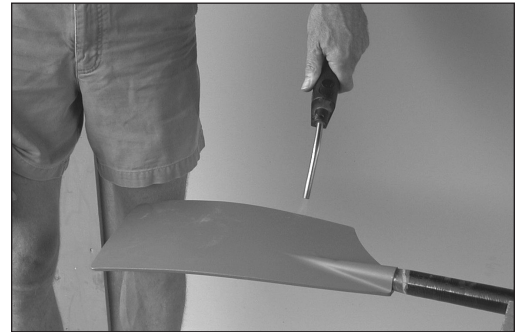

- Rotate the blade to heat the front and back evenly. Applying even heat is the most important step in removing a blade. See photo B.

photo B



2. Remove blade material:

- Use a draw knife (or any strong knife blade) to cut away a strip of the blade material to expose the shaft as shown. See photo C.

photo C



- Continue to remove blade material with the knife until the shaft is exposed as shown. Take care not to go so deep that you damage the oar shaft. See photo D.

photo D



Procedure continued

3. Pry blade:

- a. With a strong knife, pry the blade material away from the shaft. See photo E.

photo E



- b. Continue prying until the blade can be easily removed from the shaft. See photo F.

photo F



4. Remove shaft:

- a. Twist and pull the blade to remove it from the shaft. See photo G.

photo G



5. Clean shaft:

- a. Immediately after removing the blade, clean any remaining glue from the oar shaft with a knife. See photo H.
- b. Sand the shaft if necessary.

photo H

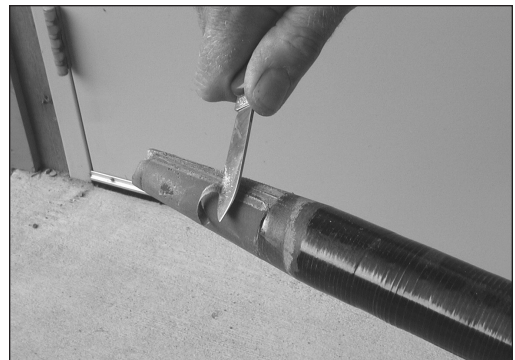

SECTION II: BONDING A BLADE

Materials Needed	Procedure Overview
<ul style="list-style-type: none">• Two-part injectable urethane glue from Concept2• Pitch Check or other means to check pitch• Paper towel or rag	<ul style="list-style-type: none">• Mix glue and spread on shaft end• Fit blade to shaft• Set pitch

Procedure

The glue used for bonding the blade sets very fast. You should review and rehearse the following instructions before mixing the glue. You may find it helpful to have two people working at this point: one to bond the blade and one to reset the pitch.

1. Check the fit of the blade(s) on the shaft(s).
Blade should slide on smoothly and snug up.
2. Have everything ready for setting the pitch. Refer to separate pitching section VII and VIII at the end of this booklet for detailed pitching instructions.
3. Mix the glue according to the instructions provided.
4. Apply the glue to the oar shaft as shown in photo A.
5. a. Fit the blade loosely onto the shaft until the pitch is reset. See photo B.
b. Twist blade on shaft 360 degrees to evenly coat the glue on the inside of the blade.
6. Set pitch following separate pitching directions in Section VII and VIII.
7. NOW fit the blade firmly onto the shaft.
8. Wipe off the excess glue. See photo C.
9. Check pitch. The pitch can be adjusted by rotating the blade on the oar while the glue is still wet.

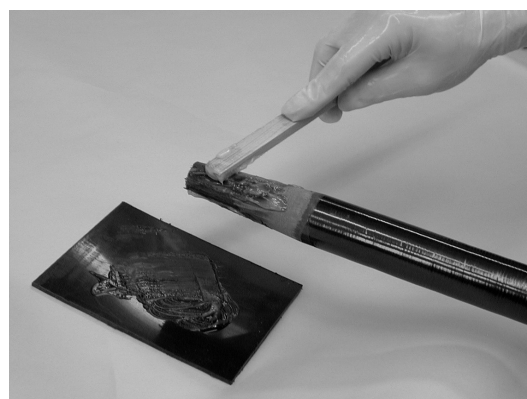

photo A

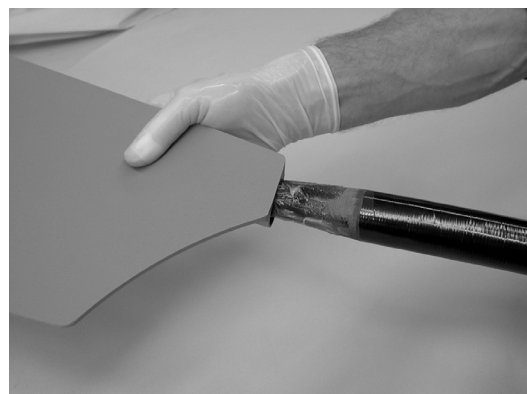

photo B

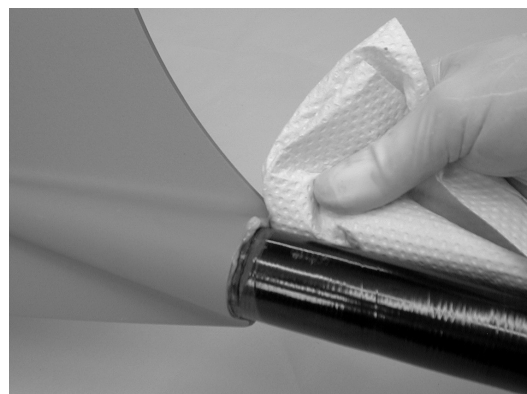

photo C

SECTION III: REPAIRING A DENT IN EDGE OF BLADE

Materials Needed	Procedure Overview
<ul style="list-style-type: none">• Small C-clamp• Scotch tape• 24-hour epoxy glue (available at hardware stores)• Three popsicle sticks or thin flat pieces of wood	<ul style="list-style-type: none">• Make a “dam” with wood and tape• Apply epoxy• Sand smooth

Procedure

1. Cover sticks with tape to keep epoxy from bonding to the stick. See photo A.

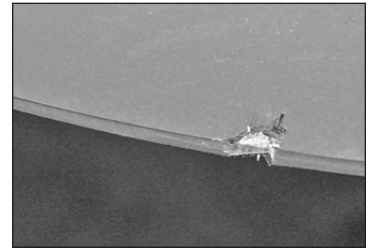

Example of dent in blade

2. Clamp sticks on either side of dent so that sticks line up with the edges of the blade. See photo B.

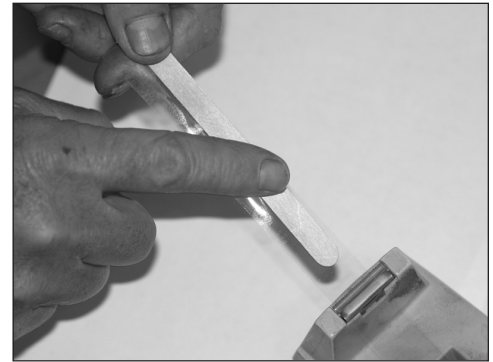

photo A

3. Fill space between sticks with epoxy. See photo C. Be sure epoxy surface is at least flush with blade edge.

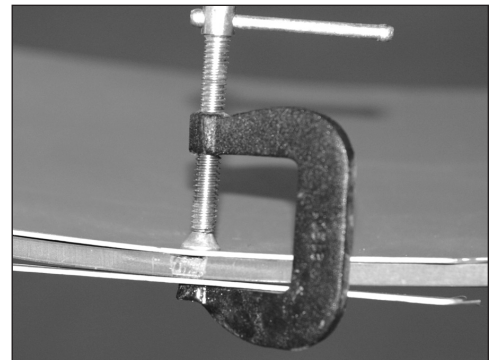

photo B

4. When the epoxy has hardened (24 hours), remove sticks and lightly sand until flush with blade surface.

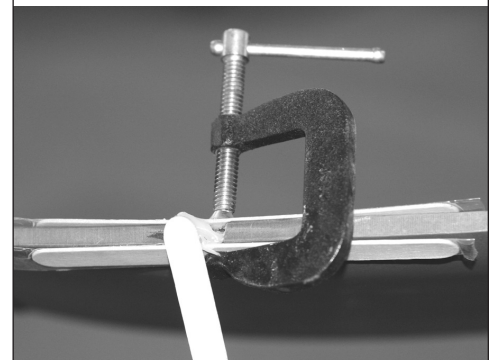

photo C

SECTION IV: REPAIRING A DELAMINATED BLADE

Materials Needed	Procedure Overview
<ul style="list-style-type: none">• 24-hour epoxy glue (available at hardware stores) or two-part urethane glue from Concept2• Spring clamp or paper clips• Knife• Sandpaper	<ul style="list-style-type: none">• Apply glue• Clamp• Sand smooth

Procedure

It is possible for a portion of the fiberglass and carbon fiber “skin” of the blade to separate due to impact at certain angles. The delaminated portion appears as a “tongue,” usually at the tip from 1/4” to 1” wide, which may extend toward the center of the blade. See photo A. This type of damage can easily be repaired with no loss of blade integrity.

1. Prepare blade:
 - a. Clean the affected area with alcohol and dry completely.
 - b. Mix the epoxy.
2. Apply the epoxy with a knife, making sure the entire area under the delaminated “tongue” is covered. See photo B.
3. Clamp and clean:
 - a. Clamp the “tongue” in its original position with the spring clamps or paper clips. See photo C.
 - b. Scrape off the excess epoxy with the knife blade.
4. When the epoxy has hardened (24 hours), sand the area to a smooth surface.

photo A

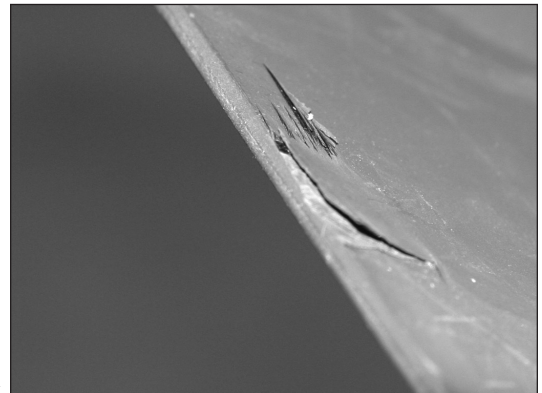

photo B

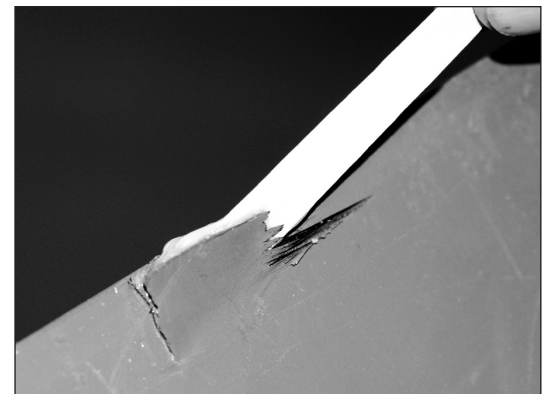
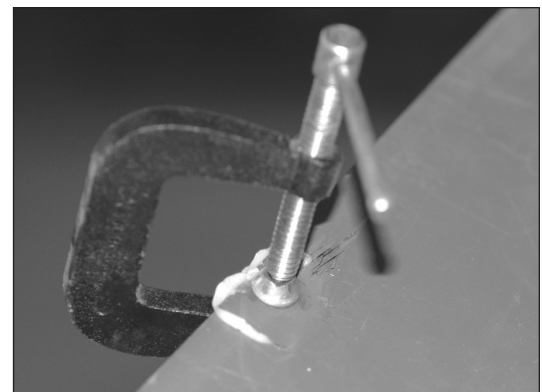

photo C



SECTION V: REPLACING AN OLD-STYLE VORTEX EDGE WITH AN OLD-STYLE VORTEX EDGE

Materials Needed	Procedure Overview
<ul style="list-style-type: none"> • Glue – any of the glues from Concept2 will work • Chisel • 120 grit sandpaper • Rubbing alcohol • Hacksaw • Spring clamps • Paper towels 	<ul style="list-style-type: none"> • Remove the old Vortex Edge • Clean off remaining glue • Attach the new Vortex Edge • Trim the ends to fit the blade

Procedure

1. Remove the old Vortex Edge by working the chisel under the edge on the back side of the blade and carefully prying the Vortex Edge up. See photo A. You may need to work all the way along the edge, prying as you go.
2. Use the chisel to scrape off any remaining glue on the blade. Use the sandpaper to scuff the blade where the new Vortex Edge will be located. Use the paper towel and alcohol to wipe off the tip of the blade.
3. Check the fit of the Vortex Edge to the tip of the blade. The wider part of the Vortex Edge goes on the back of the blade; the groove in the Vortex Edge fits over the tip of the blade. Place the Vortex Edge on the blade so that there is even spacing from the last “V” at each end of the Vortex Edge to each edge of the blade. See image B.
4. Prepare the glue and spread or inject it to fill the groove in the Vortex Edge. See photo C.
5. Peel the paper backing off the adhesive on the Vortex Edge. Place the Vortex Edge on the tip of the blade ensuring the “V”s are positioned as shown in image B. Pull the flat surface of the edge down onto the back side of the blade.
6. Rotate the Vortex Edge into position. See photo D.
Press the Vortex Edge down so that the adhesive sticks to the blade and, if necessary, use the clamps to keep the Vortex Edge in place.
7. After the glue has set, use the hacksaw to trim the excess Vortex Edge from the blade. You can smooth the cut with sandpaper if necessary.

Note: If you paint your blades, DO NOT paint the Vortex Edge.

Repairing a Loose Vortex Edge

If the Vortex Edge is merely loose at one end, lift the Vortex Edge up and spread glue between the Vortex Edge and the blade. Clamp it down with the spring clamp and wipe up any excess glue with a paper towel.

Note: If you paint your blades, DO NOT paint the Vortex Edge.

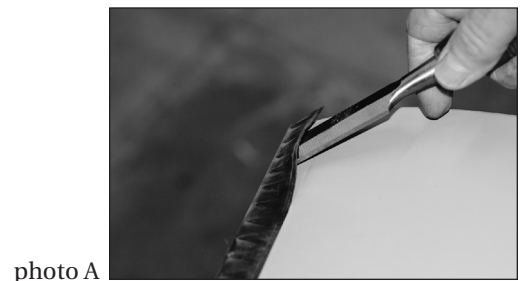

photo A

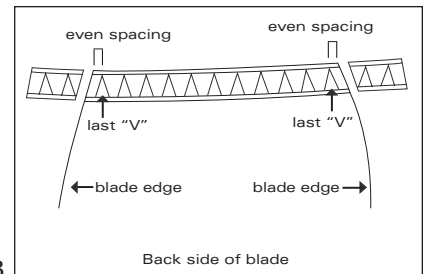

image B

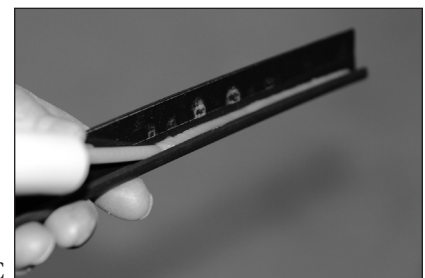

photo C



photo D

Materials Needed	Procedure Overview
<ul style="list-style-type: none"> • Screwdriver • Knife • Coping or Hack Saw • Flat and Round File • Marking Pen • Glue • Metal Template • Masking Tape 	<ul style="list-style-type: none"> • Remove old vortex edge • Mark the blade tip using the metal template • Cut the blade tip and file rough edges • Apply glue to vortex edge • Apply vortex edge to blade

Procedure

1. Remove old vortex edge. See photo A.

photo A



2. Scrape off all old glue. See photo B.

photo B

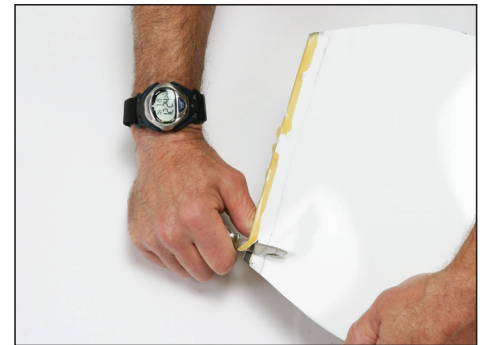

3. Line up the tip and sides of the metal template with the blade tip. Mark the blade along the edges of the template as shown. See photo C.

photo C

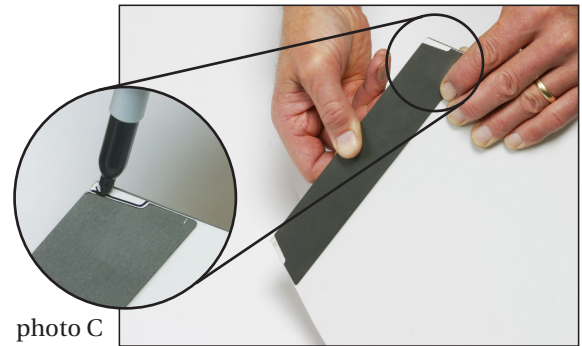

4. Cut the blade along the marked line. See photo D.

photo D



Procedure continued

5. Using the flat and/or round file, file rough edges.
See photo E.

photo E

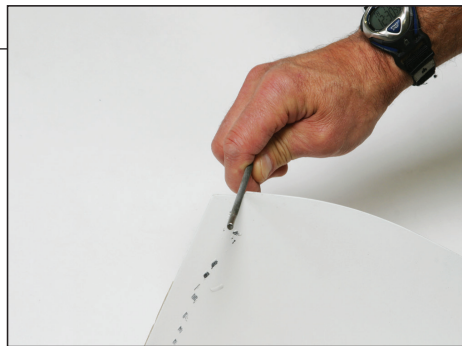

6. Check that the vortex edge fits over the tip of the blade. Note that the smooth side of the vortex edge is on the same side as the blade face. Refile blade as needed. See photo F.

photo F



7. Deposit several dollops of glue in the vortex edge. Use no more than 1 tablespoon (15 ml) of glue per vortex edge. See photo G.

photo G



8. Install vortex edge on the blade. Allow ½ hour to dry. You may want to use masking tape to hold the vortex edge in place while the glue dries. See photo H.

photo H

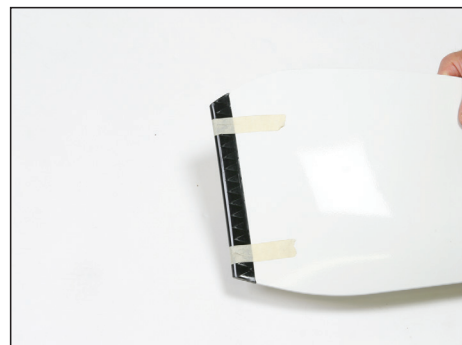

9. File edges of the vortex edge and the blade until smooth. See photo I.

photo I



SECTION VII: REPLACING A CAP-STYLE VORTEX EDGE

Materials Needed	Procedure Overview
<ul style="list-style-type: none">• Screwdriver• Knife• Glue	<ul style="list-style-type: none">• Remove old vortex edge• Scrape off old glue• Apply glue to vortex edge• Apply vortex edge to blade

Procedure

1. Remove old vortex edge and scrape off all old glue . See photos A and B.



photo A

photo B

2. Check that the vortex edge fits over the tip of the blade. Note that the smooth side of the vortex edge is on the same side as the blade face. See photo C.



photo C

3. Deposit several dollops of glue in the vortex edge. Use no more than 1 tablespoon (15 ml) of glue per vortex edge. See photo D.



photo D

4. Install vortex edge on the blade. Allow ½ hour to dry. You may want to use masking tape to hold the vortex edge in place while the glue dries. See photo E.

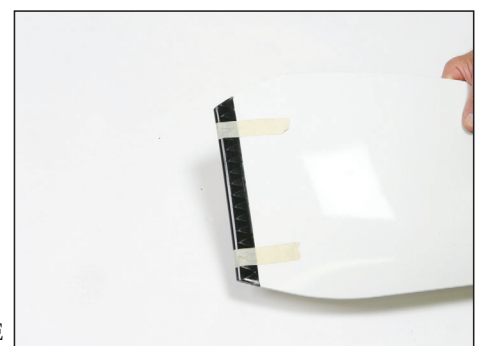

photo E

Paint Recommendations

Your blades have been finished with an abrasion-resistant epoxy powder coat system. With appropriate preparation, this finish is compatible with most other finish coats such as acrylic enamel, acrylic urethane, urethane, or epoxy paint. If you would like to change your blade color or apply additional paint or designs, prepare your blades for painting as described below.

Recommended paints for brush application:

AWLGRIP – Polyester Urethane Topcoat Base (Color)
H3002 Brush Catalyst*
T0031 Thinner*

Interlux – Brightside—Polyurethane
333 Brushing Thinner*

Pettit – Easyepoxy Topcoat—Polyurethane
Tie Coat Primer 6627*

*Must be used in combination with the paint.

We recommend reading through the entire procedure before you begin painting your blade.

Vinyl Recommendations for Carbon Fiber Blades

Many customers choose a solid color factory finish from Concept2, then add unique designs (such as stripes) with decals. New decal materials are easy to apply, replaceable, and don't suffer from the "bubbling" typical of more traditional vinyl materials.

Two products we recommend are 3M™ Wrap Film Series 1080 and Avery® WS900 Supreme Wrapping Vinyl Film, both of which can be found from many stores online (Concept2 does not sell material directly). We recommend testing any vinyl decals before racing.

Painting Factory-Finished Blades

(Blades finished with the **standard white powder coat** manufactured November 2009 to present or the **standard white urethane** manufactured 2007 to November 2009.)

Materials Needed	Procedure Overview
<ul style="list-style-type: none"> • 220 grit sandpaper • Orbital sander (optional) • Rubbing alcohol • Lint-free cloth • Gray spray primer for guide coat • Paint brushes—foam or bristle • Plastic paint container (quart size) • Paint products • Safety glasses • Latex gloves • Protective respirator mask 	<ul style="list-style-type: none"> • Apply a primer guide coat and sand both sides of blade • Clean blade with rubbing alcohol • Test paint on small portion of blade • Paint both sides of blade and recoat as needed

Procedure

1. Using gray spray primer, apply a light dusting, or “guide coat,” of primer on both sides of the blade from a distance of 18–20 inches. The gray primer will act as a visual guide when sanding and will expose any low spots or imperfections during the surface prep. Allow to dry for 5–10 minutes.
2. With 220 grit paper, hand sand or use an orbital sander to sand both sides of the blade to a dull finish. (An orbital sander will provide the best prep with the least amount of effort.) **IMPORTANT:** Proper paint adhesion requires that the blades are thoroughly sanded.
 - a. To sand by hand:
Start sanding in a corner of the blade. Work your way across the blade surface removing all previously applied guide coat. Sand the other side.
 - b. To sand with an orbital sander:
Sand the back surface of the blade up to and around the cone area. Hand sand the cone area. Sand the front of the blade.
3. Using rubbing alcohol on a lint-free cloth, wipe both sides of the blade to remove the sanding dust. Allow the alcohol to evaporate completely.

IMPORTANT: Before priming and painting your blade:

- a. Mix and apply the primer/paint per the manufacturer’s instructions.
 - b. Test the primer/paint on a small portion of the sanded blade to ensure that it does not bubble or easily scrape or peel off.
 - c. **DO NOT** paint the Vortex Edge.
4. Prime the blade with a primer that is compatible with the finish coat you are using. Follow the instructions from the primer manufacturer to prepare the primer.
 5. Mix the paint (and thinner if appropriate) per the manufacturer’s instructions. Using a bristle or foam brush, apply paint in light coats starting with the edges of the blade, making sure to smooth excess paint on both blade surfaces. Start at one end of the blade surface and apply the paint in smooth, even strokes. Allow the paint to dry per the manufacturer’s instructions before recoating to your desired finish.
Note: One coat will not provide good results. We recommend lightly applying multiple coats. Applying thick coats may produce paint runs and improper curing.

Note:

If your oars have the Vortex Edge, **DO NOT** paint the plastic vortex edge cap.

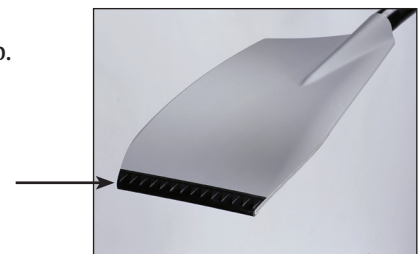

SECTION VIII: PAINTING BLADES

Painting Factory-Finished Blades

(Blades finished with a custom paint color from Concept2's Custom Urethane Color Option System)

Materials Needed	Procedure Overview
<ul style="list-style-type: none">• 220 grit sandpaper• Rubbing alcohol• Lint-free cloth• Paint brushes—foam or bristle• Paint products	<ul style="list-style-type: none">• Sand both sides of blade• Clean blade with rubbing alcohol• Test paint on small portion of blade• Paint both sides of blade and recoat as needed

Your blades have been finished with a custom color from Concept2's Urethane Color option system at the Concept2 factory. With appropriate preparation, these finishes are compatible with most other finish coats such as acrylic enamel, acrylic urethane, urethane, or epoxy paint. If you would like to apply additional color(s) or apply additional designs, prepare your blades for painting as follows:

1. Sand the portion of blade to be painted with 220 grit sandpaper.
2. Wipe the blade clean with alcohol or automotive paint degreaser.
3. **IMPORTANT:** Test the paint on a small portion of your blade before painting the entire blade. Let the paint dry completely to assure proper adhesion. Be sure it does not bubble or easily scrape or peel off. If it does, please contact Concept2 for assistance.
4. Spray or brush the rest of the blade with your finish coat of paint.

Note: If your oars have the Vortex Edge, DO NOT paint the plastic vortex edge cap.



SECTION VIII: PAINTING BLADES

Painting Blades Manufactured in 2006 and Earlier

Paint Recommendations

AWLGRIP – Polyester Urethane Topcoat Base (Color)
H3002 Brush Catalyst*
T0031 Thinner*

*Must be used in combination with the paint.

Materials Needed	Procedure Overview
<ul style="list-style-type: none">• 220 grit sandpaper• Rubbing alcohol• Lint-free cloth• Paint brushes—foam or bristle• Paint products	<ul style="list-style-type: none">• Sand both sides of blade• Clean blade with rubbing alcohol• Test paint on small portion of blade• Paint both sides of blade and recoat as needed

Procedure

The gray primer is designed to be finish-coated with automotive or marine grade acrylic enamel paint. Polyurethane paints are not compatible with the gray primer. If you would like to paint your gray blades, prepare your blades for painting as follows:

1. Sand the blades lightly with 220 grit sandpaper.
2. Wipe the blades clean with alcohol or automotive paint degreaser.
3. **IMPORTANT:** Test the paint on a small portion of your blade before painting the entire blade. Let the paint dry completely to assure proper adhesion. Be sure it does not bubble or easily scrape or peel off. If it does, please contact Concept2 for assistance.



Note: If your oars have the Vortex Edge, DO NOT paint the plastic vortex edge cap.

Painting the Compact Blade

The Compact blade, standard on Bantam Sculls, is made of polypropylene, a similar thermoplastic as the bumpers on most cars today. You must use a paint system formulated for this type of plastic (also referred to as PP or TPO), or the paint will not stick.

We recommend shopping at your local auto supply store for “bumper paint” for the base color of your blade. A bumper paint system may include a cleaner and an “adhesion enhancer” or primer. **FOLLOW THE MANUFACTURER’S INSTRUCTIONS.**

We have tested these brands with good success:

- SEM®
- Dupli-color®
- Urethane Supply Company® brands

Test one side of one blade first before painting a fleet of blades. Follow the manufacturer’s instructions for how to add additional designs or stripes to your base color.

SECTION IX: PITCHING ORIGINAL SMOOTHIE1 AND FAT BLADES

(All blades made from the older 1996–2006 Smoothie1 mold) with or without Vortex Edge

Materials Needed	Procedure Overview
<ul style="list-style-type: none"> • Digital level or pitch meter • Level surface • Square-sided level or level block of wood 	<ul style="list-style-type: none"> • Set up the level block for the blade. • Check pitch at the sleeve using a digital level or pitch meter

There are a number of methods used to check the pitch on oars and sculls. The easiest way to measure pitch on Concept2 products is to use the Pitch Check available from Concept2. If you do not have a Pitch Check, the following instructions reflect the methods used at Concept2 to check and set pitch. If you want to check the pitch on your oars, we recommend that you use these same methods, as other methods may give you different results.

Note: Be sure to use the appropriate method for the type of blade you have.

Procedure

1. When measuring the pitch on a Smoothie or “Fat” Smoothie Vortex blade, do not include the curved portion at the top edge of the blade.
2. Ensure the oar shaft is level.

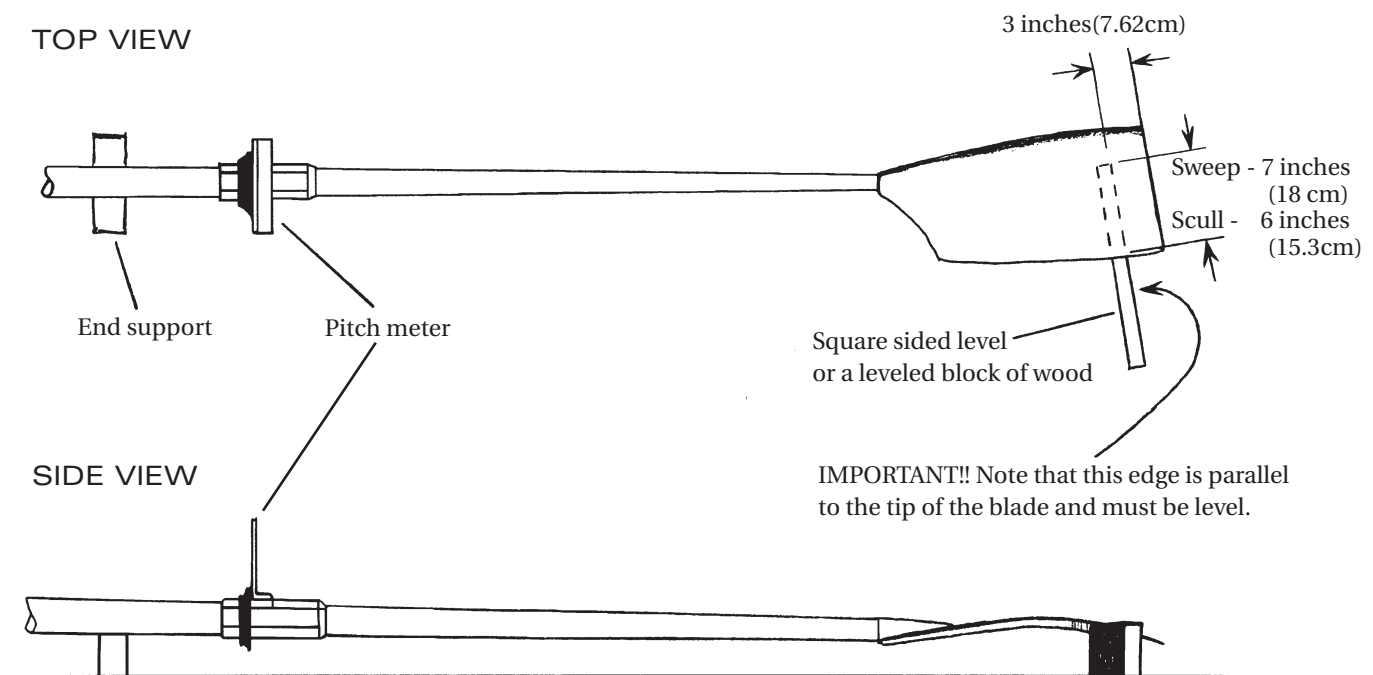

continued on next page

Procedure continued

- Our standard procedure was to ship Smoothie1 blades with the pitch set so the oar could be put into rigging that was set for a Big Blade, with no adjustment required.

The Smoothie1 performs best with the flat surface of the blade pitched at 2 degrees during the drive. Thus, if you use the Smoothie1 in an oarlock pitched at 5 degrees, the result at the blade face will be the desired 2 degree pitch.

$$5^{\circ} - 3^{\circ} = 2^{\circ} \text{ net pitch at blade face.}$$

- Set the sleeve at 2° relative to the flat blade surface as shown in diagram at right.

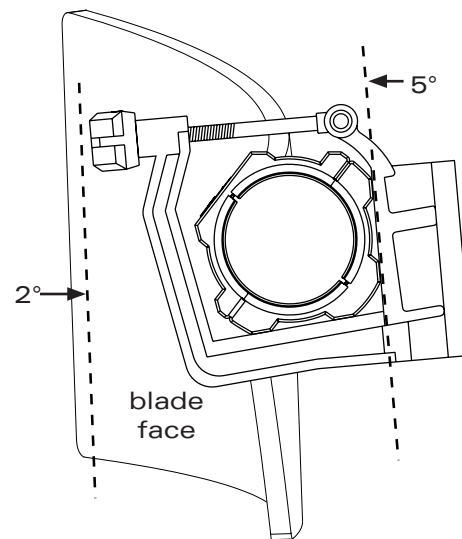
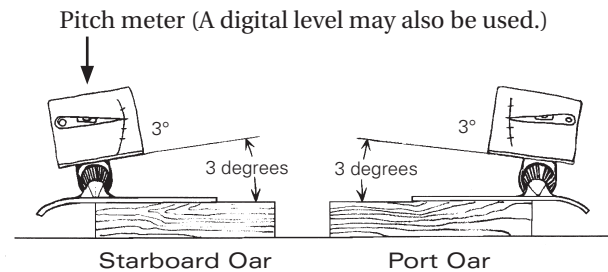

SECTION X: PITCHING MACON, BIG BLADE, SMOOTHIE2 AND FAT2 BLADES

(All blades made from the older 2007 Smoothie2 mold and 1987 traditional hatchet blade mold) with or without Vortex Edge

Materials Needed	Procedure Overview
<ul style="list-style-type: none"> • Level • Level surface • Square-sided level or level block of wood 	<ul style="list-style-type: none"> • Set up the level block for the blade. • Check pitch at the sleeve using the level

There are a number of methods used to check the pitch on oars and sculls. The easiest way to measure pitch on Concept2 products is to use the Pitch Check available from Concept2. If you do not have a Pitch Check, the following instructions reflect the methods used at Concept2 to check and set pitch. If you want to check the pitch on your oars, we recommend that you use these same methods, as other methods may give you different results.

Note: Be sure you use the appropriate method for the type of blade you have.

Procedure

1. Clamp a piece of wood or steel to one end of a bench or other stable structure. This block should have an even top surface and must be at least as long as your blade is wide.
2. Using a bubble level and shims, level the block and secure it to the bench.
3. Position a support block ("V" blocks are helpful here) to hold the handle end of the oar off the bench.
4. Place the blade of the oar face side down on the block, with the short side corner of the blade extending 1 inch beyond the edge of level block.

Note: The centerline of the oar **must** be perpendicular to the level block.

5. Position your level on the wear surface of the sleeve. If the surface is level, then the oar has zero pitch. If the surface is not level, then raise one edge of the level until it shows level. This will show you how much sleeve material will have to be removed to correct the pitch to zero.

You may fine tune the pitch as much as one-half (0.5) degree by filing or scraping down the wear surface.

6. Use an adjustable pitch level for checking oars with a designated pitch other than zero.

SIDE VIEW

